

POWERMATIC EVOLUTION^{VSD}



KEY FEATURES

- Auto Regulated Current Control for Low Voltage
- No Circuit Breaker Trip Outs with Multiple Current Drawing Devices
- Quiet Operation with Reduced Standby Speed & Noise Level
- Hinged Compaction Chamber for Easy Bale Removal
- Lowest Overall Height & Width Woolpress Available
- Remote Access Control Monitoring via Mobile Phone
- Electric Motor protection Against Low Voltage
- Reduced Power Consumption & Operational Costs

INNOVATIVE LEADING EDGE TECHNOLOGY

MACBRO'S NEW EVOLUTION
Programmable Woolpress with
Intelligent Power Optimiser +
Variable Current & Speed Control

KEY BENEFITS

- Flexible Single-Phase Input (180v – 250v AC)
- High Efficiency 2.8Kw No Capacitor 3 Phase Electric Motor
- Variable Current & Speed Control
- Automatic Warm Up Cycle Function
- Loadcell Digital Scales
- Heavy Duty 2.5mm / 8 Metre 240AC Power Cable
- Rodent Proof Rubber Coated Steel Conduit on Cables
- Lower Operating Temperature for Hydraulic Oil & Electric Motor
- Back Up Generator & Solar Power Compatible

KEY PROBLEMS SOLVED

- Low Supply Voltage / Current
- No Circuit Breaker Trip Outs
- Operating Multiple Devices Simultaneously
- Low Operating Noise Levels
- No Motor or Clutch Failures

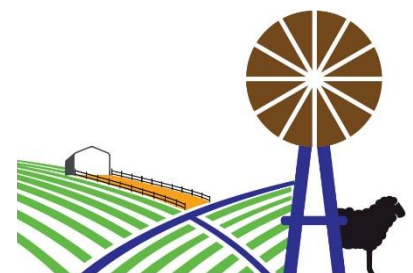

25 Moorundie St. TRURO SA. 08 8564 0214
sales@truroagencies.com.au : www.truroagencies.com.au

TRURO
SHEAR GEAR

POWERMATIC EVOLUTION^{VSD}

POWERMATIC EVO WOOLPRESS
EXPERT DESIGN & PERFORMANCE

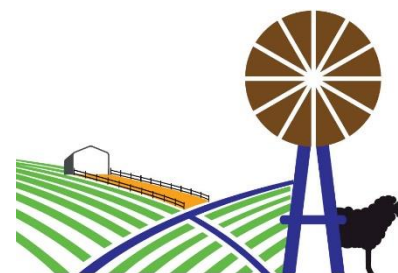
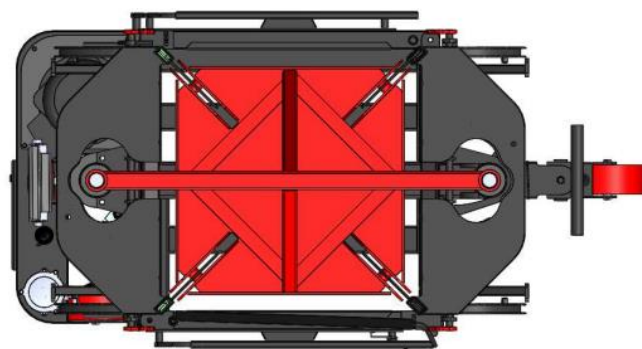
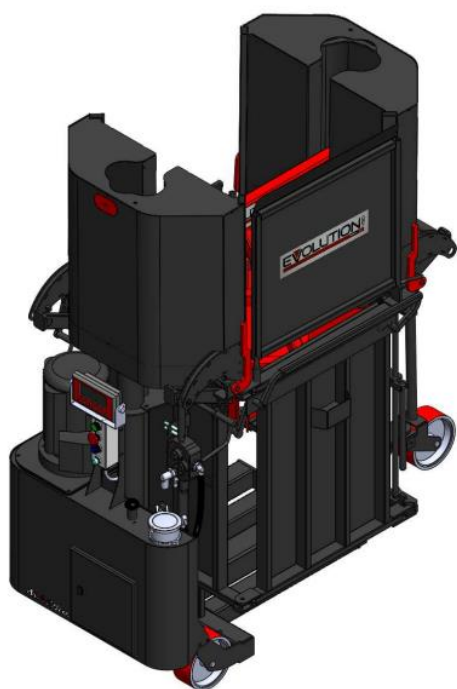
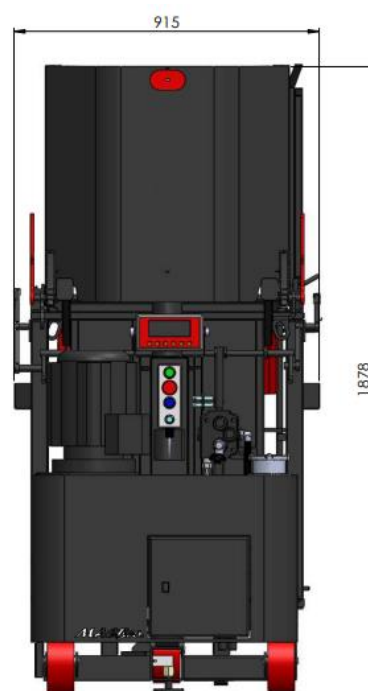
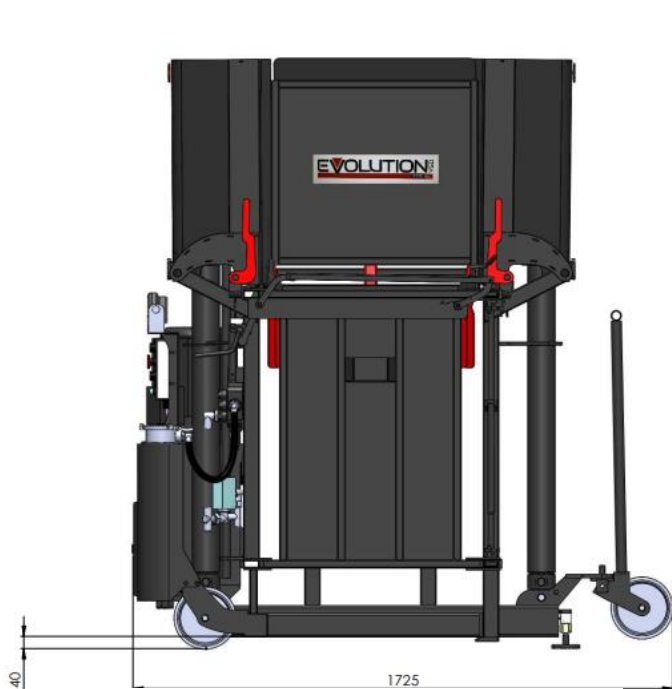

25 Moorundie St. TRURO SA. 08 8564 0214
sales@truroagencies.com.au : www.truroagencies.

TRURO
SHEAR GEAR